

FPS

Slip Rings for Flowpack Machines



FPS – the Slip Rings for your Flowpack Machine

Standard Version

Dimensions:

- Length: 106 mm
- Height: 94 mm
- Width: 59 mm

- 1 Power:** 2+PE / 220 V / 12 A
- 2 Signals:** 2 x silver plated rings
+ silver based brushes
- **Rotational speed** up to 500 rpm
- **Lifetime** up to 500 million revolutions
- 3 Connection** hub with 3 x socket set screws
- 4 Antirotation slot** integrated in the slip ring body
- 5 Enclosure:** IP65 – no dust & liquids penetration,
safely contains wearing dust from the slip ring. No accessible
live part when energized and under tension: **safe and clean**

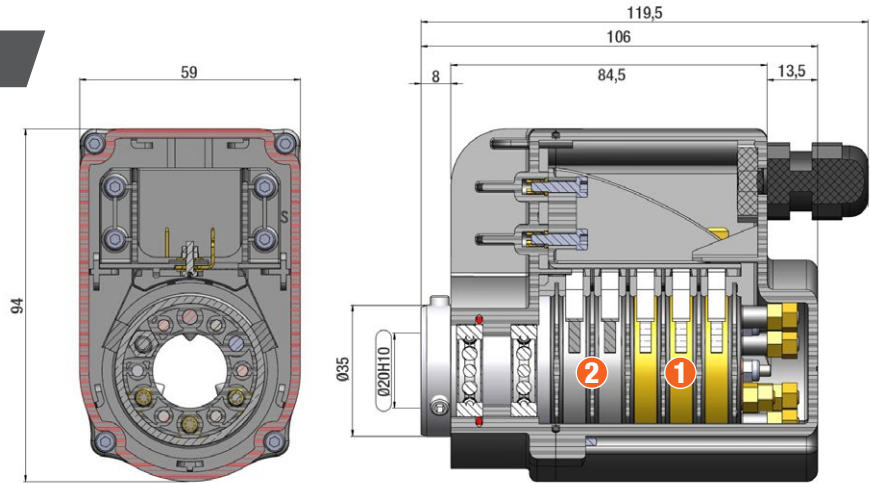

Serviceability: Unique FPS Features

- 6 Opening:** full access for wiring & easy cleaning
- 7 Wiring on rings:** threaded rods + nuts: **reliability**
- 8 Wiring on Brush Holders** with faston terminals: **fast & easy**

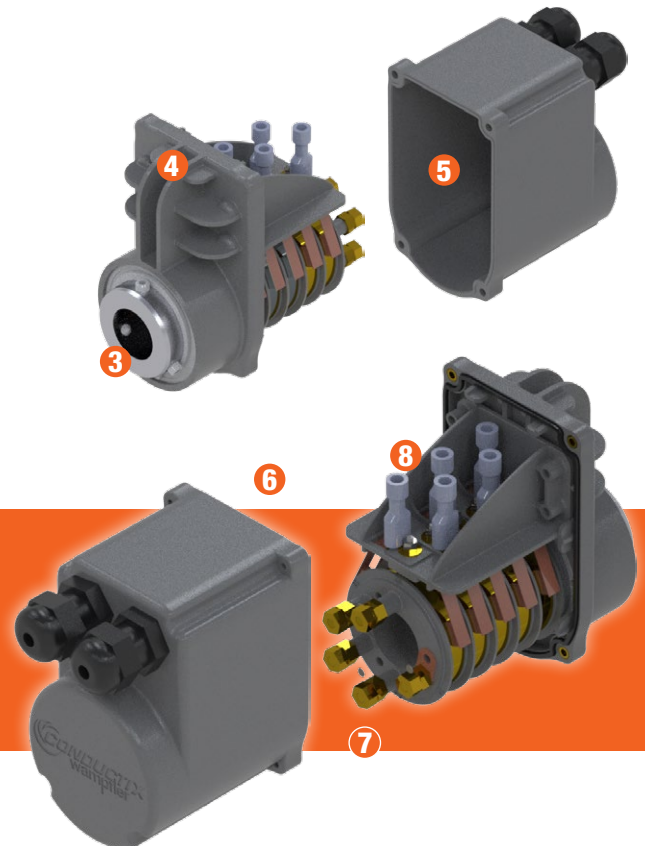

FPS – adjustable to your specific needs

Options and Variants

- 1 Pole numbers** from 2 to 10
 - to have any required composition of power/signals
 - higher ampacity (>12 A) on request

Customized enclosure (PA12 3D-printed)

- 2** multiple **cable glands position**
- 3** custom **antirotation slot**
- 4** **Spring Terminals** on brushes side
 - to have faster and safer wiring in case of strong vibrations
- 5** **Separate wiring chamber** for rings and brushes terminals
 - to clean the slip ring outside the machine avoiding dust contamination

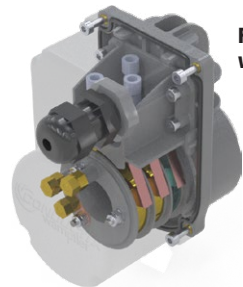

FPS special
with 3 poles

1

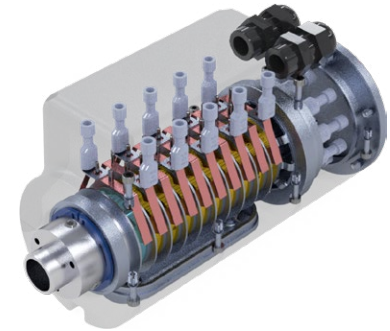

FPS special
with 10 poles



2



3

Separate wiring
chamber and
terminals on
brushes side

4



5

Separate wiring chamber on rings side

FPS Slip Rings:

- Safe
- Reliable
- Easy to Clean



www.conductix.com

Conductix-Wampfler has just one critical mission:
To provide you with energy and data transmission
systems that will keep your operations up and
running 24/7/365.

To contact your nearest sales office, please refer to:
www.conductix.contact

